

# Omnitracs SR4 International DuraStar (MA025) Installation Guide

This VSA covers models manufactured between 2001-2019



Manufactured by Navistar Inc.



Produced between 2001-2019. Replaced by International MV Series.

# International DuraStar (MA025)

## Cable Guide **2001-2019**



Durastar  
(Flat windshield)

Year Range	SR4 Harness Description	SR4 SKU	Cable Type
2001-2016 Released 2001	J-1939 and J1708 9 Pin Type 1, Black flange	104-0009-0018-00	 J-1939, 9-pin Type 1, (Black) Flange
2017-2019 Last year 2019	J-1939, 9 Pin Type 2, Green Flange	104-0009-0005-00	 J-1939, 9-pin Type 2, (Green) Flange

# International DuraStar (MA025)

Approved camera mounting (flat windshield), sensor bar, and keypad locations

**Note: Any combination of these mounting locations are approved**

## Flat windshield - Preferred locations

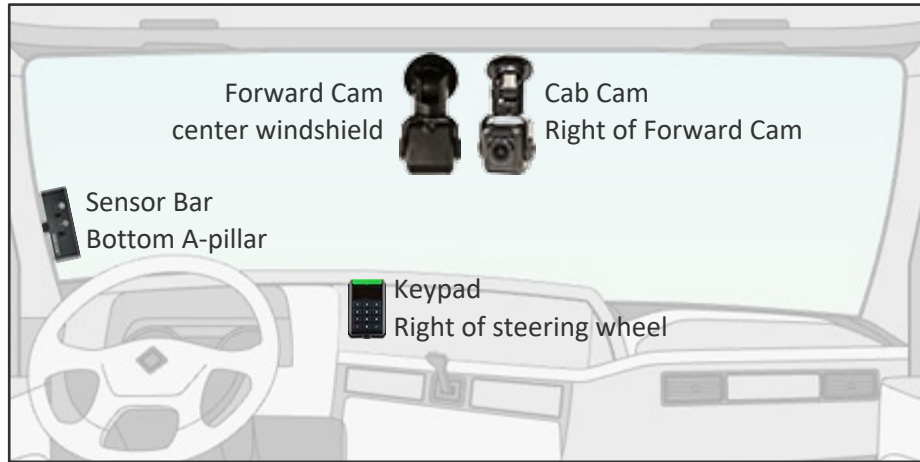

## Flat windshield - Alternative locations

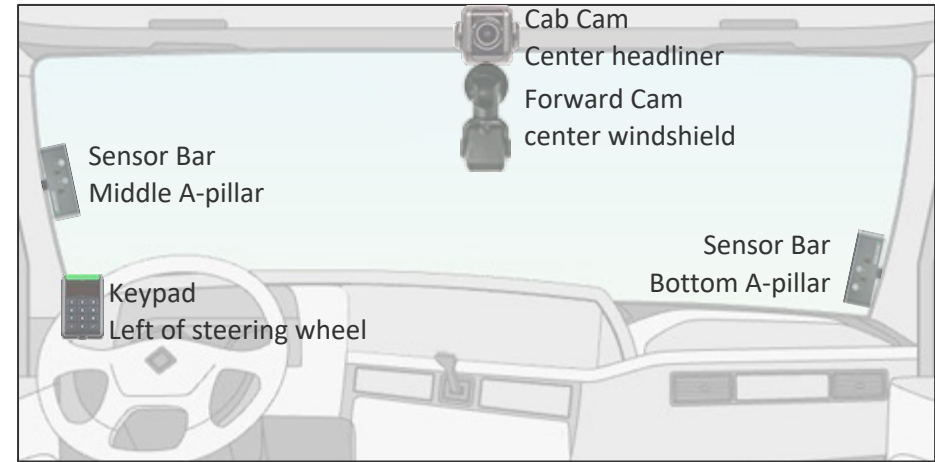

## Split windshield - Preferred locations

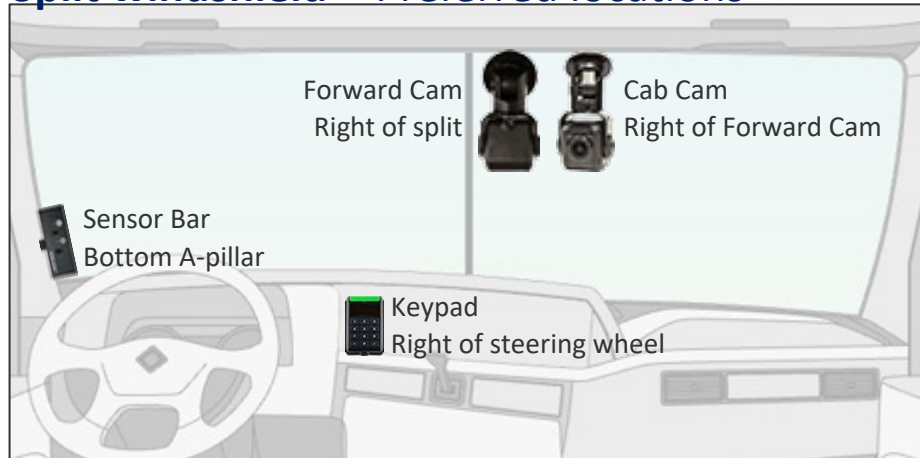

## Split windshield - Alternative locations

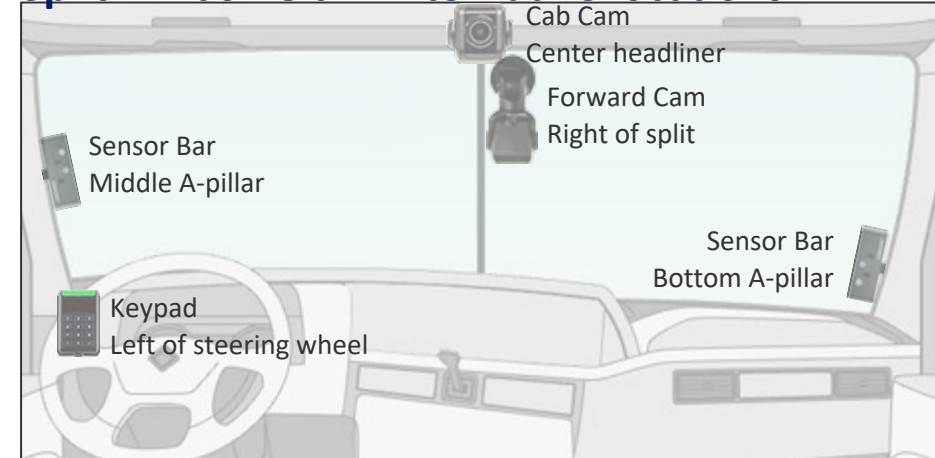

# International DuraStar (MA025)

Approved camera mounting (flat windshield), sensor bar, and keypad locations

**Note: Any combination of these mounting locations are approved**

## Flat windshield - Preferred locations

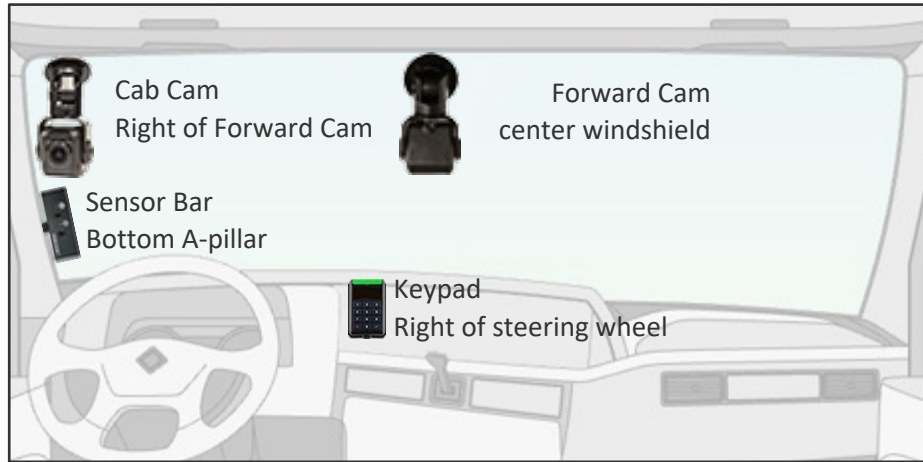

## Flat windshield - Alternative locations

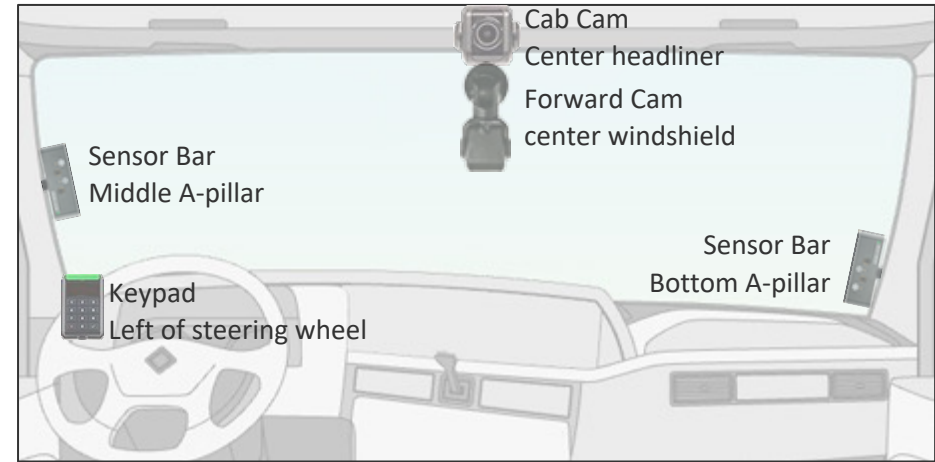

## Split windshield - Preferred locations

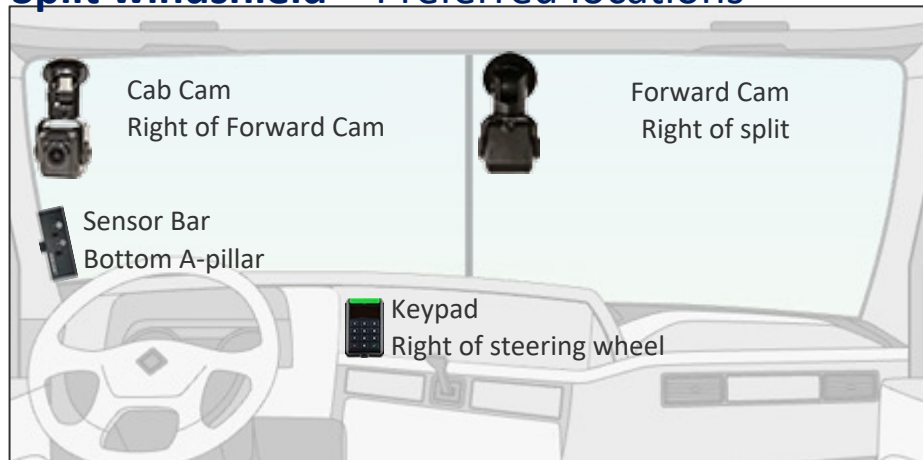

## Split windshield - Alternative locations

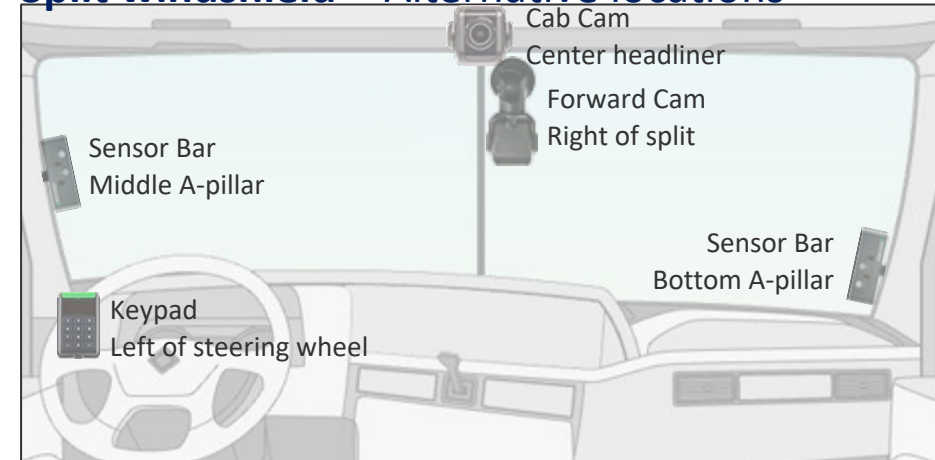



---

# 2001 - 2016 DLC and wiring instructions

---

# International DuraStar (MA025)

Approved controller, ECU, and wiring locations

2001-2016

Component	Primary location <span style="float: right; border: 1px solid black; border-radius: 50%; padding: 2px 5px;">1</span>
Controller	Center dash
ECU Port	Driver-side bottom dash J-1939 & J1708 9 Pin Type 1, Flange black (104-0009-0018-00)
Wiring Constant, True Ignition, & Ground	Passenger-side Fuse Box

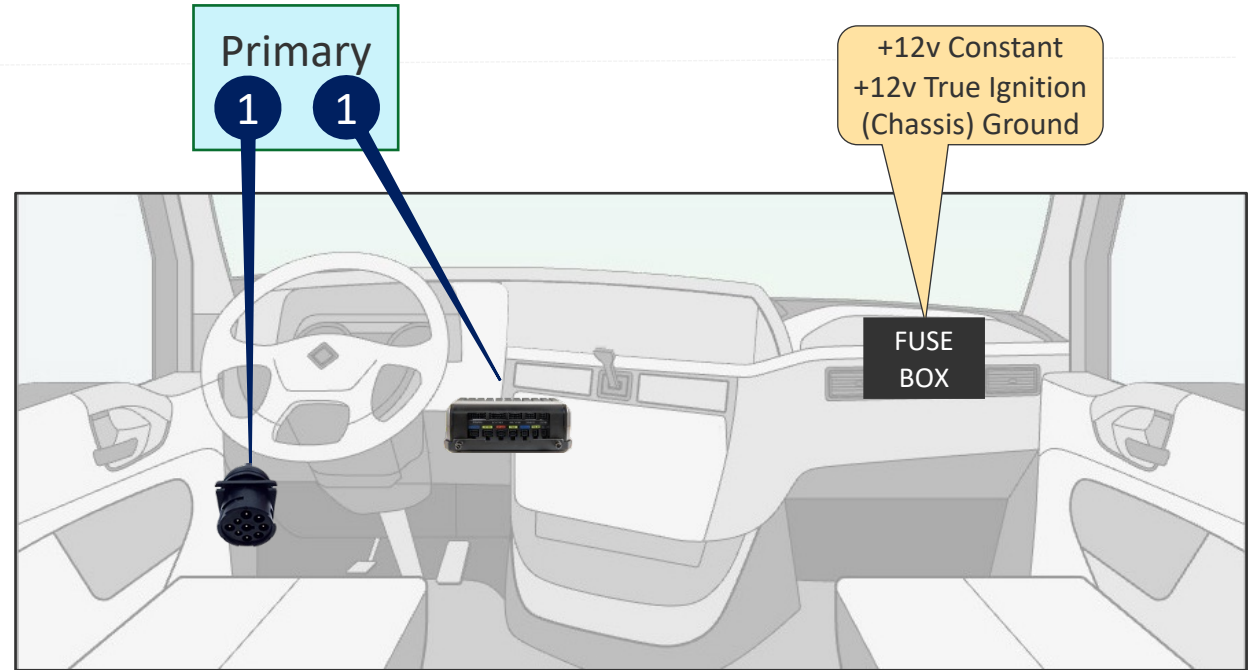

# International DuraStar (MA025)

## 2001-2016: Wiring connections

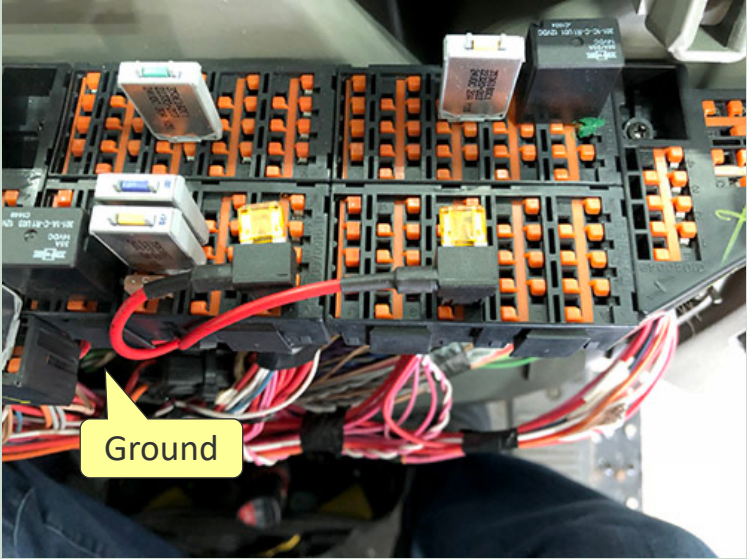
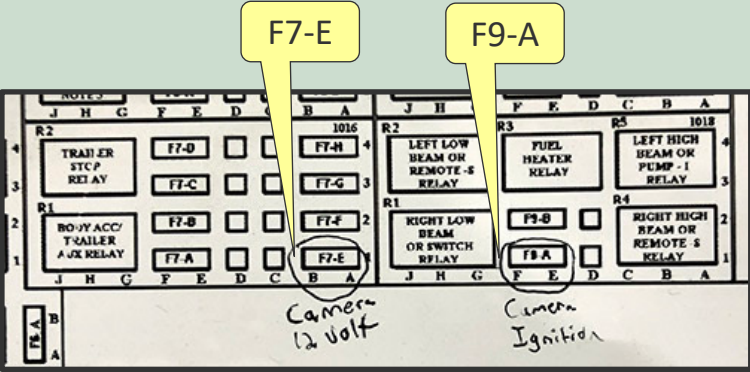
Fuse box Location	Wiring Diagram	Wiring Locations
<p data-bbox="343 292 667 371">Passenger side behind the glove box</p>  <p data-bbox="216 849 369 899">Ground</p>	 <p data-bbox="1166 349 1274 392">F7-E</p> <p data-bbox="1363 349 1470 392">F9-A</p> <p data-bbox="1184 635 1286 692">Camera 12 Volt</p> <p data-bbox="1401 635 1503 692">Camera Ignition</p>	<p data-bbox="1719 292 1974 321"><b>Constant Power</b></p> <p data-bbox="1719 335 2420 464">Add-A-Fuse Slot F7-E Alternative- Butt connector to <b>RED</b> flying lead under fuse box if available</p> <p data-bbox="1719 606 1923 635"><b>True Ignition</b></p> <p data-bbox="1719 649 2420 778">Add-A-Fuse Slot F9-A Alternative- Butt connector to <b>PINK</b> flying lead under fuse box if available</p> <p data-bbox="1719 871 1847 899"><b>Ground</b></p> <p data-bbox="1719 913 2420 992">Use a #10 ring terminal and connect to chassis near the fuse panel</p>

See the [WIRING CONNECTION INSTRUCTIONS](#) slide for details

# International DuraStar (MA025)

2001-2016 9-PIN type 1 Flange Data Link Connector (DLC)

Component		Notes
9-Pin Type I Flange (Black)		N/A

Description		
SR4 Part#	104-0009-0018-00	J-1939, 9 Pin Type 1, Flange black
Connector Color	Black	( <u>Black</u> ) color indicates J1939, 250kb network speed
Network	J1939 & J1708	Vehicle Bus Communication Network - (Passive)
Baud Rate	250kb	<ul style="list-style-type: none"><li>Supports (250kb) low speed protocol</li><li>(<u>250kb</u>) Best Connection for 3<sup>rd</sup> Party Devices</li></ul>
Connection Type	9-PinType 1, Flange	Square mounting tab located near the connectors base with slots for mounting screws.





---

# 2017–2019 DLC and wiring instructions

---

# International DuraStar (MA025)

Approved controller, ECU, and wiring locations

2017-2019

Component	Primary location <span style="float: right; border: 1px solid black; border-radius: 50%; padding: 2px 5px;">1</span>
Controller	Center dash
ECU Port	Driver-side bottom dash J-1939, 9 Pin Type 2, Flange green (104-0009-0005-00)
Wiring Constant, True Ignition, & Ground	Passenger-side Fuse Box

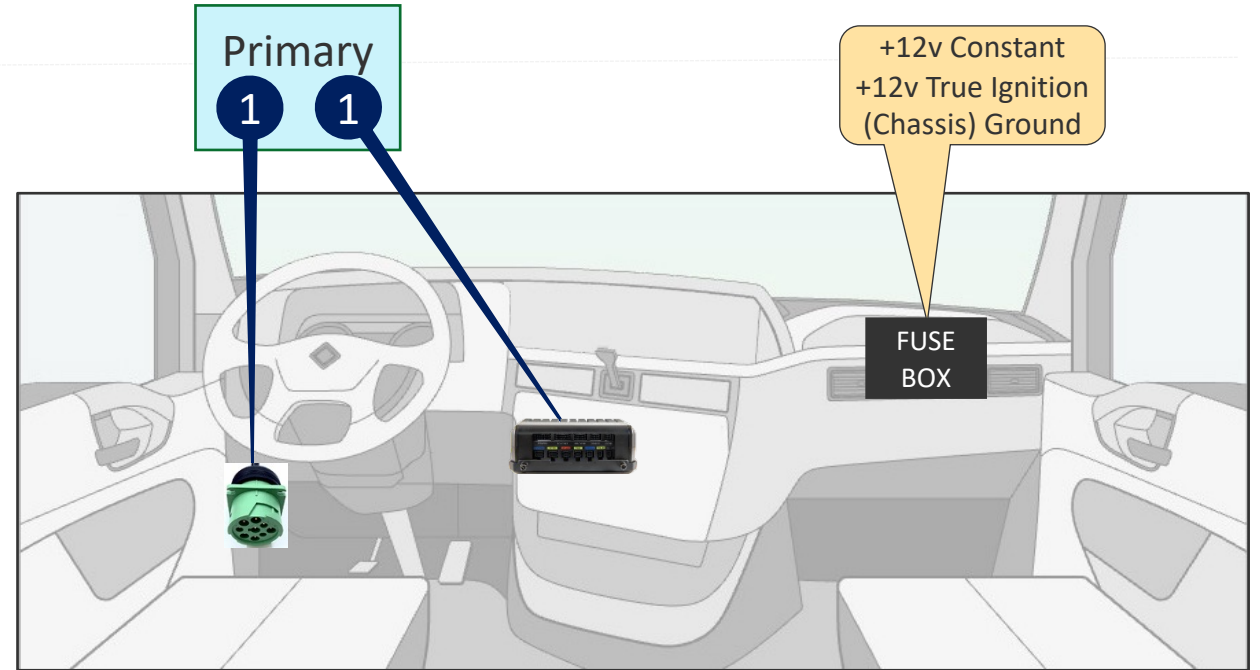

# International DuraStar (MA025)

2017-2019 Constant power, true ignition, and ground wiring connections

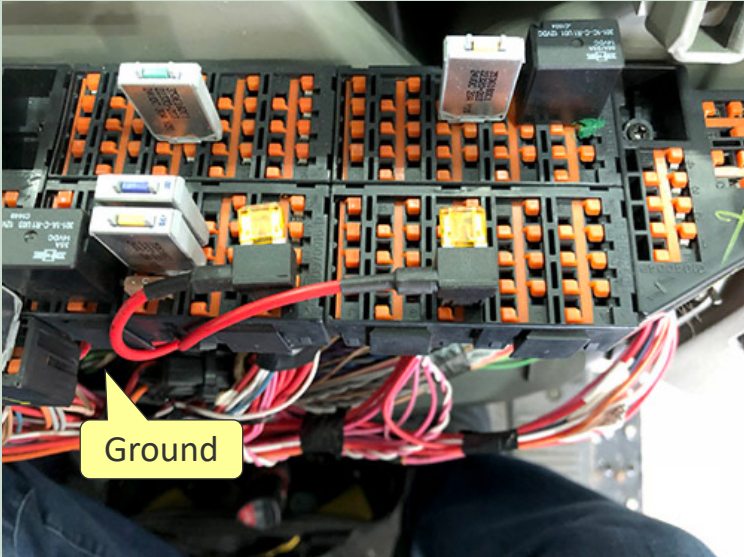
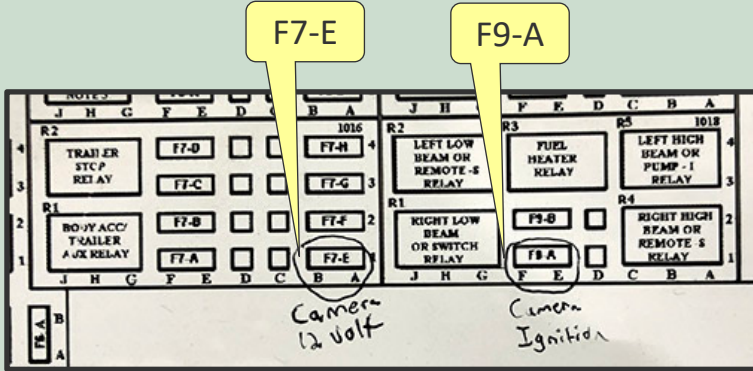
Fuse box Location	X6 Connector	Wiring Locations
<p data-bbox="343 325 665 401">Passenger-side behind the glove box</p>  <p data-bbox="216 853 369 896">Ground</p>	 <p data-bbox="1174 354 1268 396">F7-E</p> <p data-bbox="1370 354 1465 396">F9-A</p> <p data-bbox="1192 639 1286 682">Camera 12 Volt</p> <p data-bbox="1409 639 1503 682">Camera Ignition</p>	<p data-bbox="1694 325 1939 358"><b>Constant Power</b></p> <p data-bbox="1694 372 2382 486">Add-A-Fuse Slot F7-E Alternative- Butt connector to <b>RED</b> flying lead under fuse box if available</p> <p data-bbox="1694 639 1888 672"><b>True Ignition</b></p> <p data-bbox="1694 686 2397 801">Add-A-Fuse Slot F9-A Alternative- Butt connector to <b>PINK</b> flying lead under fuse box if available</p> <p data-bbox="1694 911 1811 943"><b>Ground</b></p> <p data-bbox="1694 958 2397 1022">Use a #10 ring terminal and connect to chassis near the fuse panel</p>

See the [WIRING CONNECTION INSTRUCTIONS](#) slide for details

# International DuraStar (MA025)

## 2017-2019 9-PIN Type 2 Flange Data Link Connector (DLC)

Component		Notes
9-Pin Type 2 Flange (Green)		N/A

Description		
SR4 Part#	104-0009-0005-00	J-1939, 9 Pin Type 2, Flange black
Connector Color	Green	(Green) color indicates J1939, 500kb network speed
Network	J1939	Vehicle Bus Communication Network - (Passive)
Baud Rate	250kb, 500kb	<ul style="list-style-type: none"><li>Supports (250kb) Low speed and (500kb) High speed</li><li>(250kb) Best Connection for 3rd Party Devices</li></ul>
Connection Type	9-Pin, Type 2, Flange	Square mounting tab located near the connectors base with slots for mounting screws.







# 360 Camera Side-mirror Installation

# International DuraStar (MA025)

Approved 360 Camera VSA

The following 360 Convoy VSAs describe the installation process.

- SR4-360 VSA\_Side Mirror
- SR4-360 VSA\_Rear view
- SR4-360 VSA\_Entry Exit Door
- SR4-360 VSA\_Inside Interior
- SR4-360 VSA\_Monitor M7104
- SR4-360 VSA\_5 Camera

Please contact your Project Manager for a copy of these documents.

## SmartDrive™ SR4 360 VSA

### 360 Convoy Mirror-Mount Side Camera

Installation Quality Standards



The image shows three camera units: C1600SD-LR (bottom of mirror), Driver side, left, and Passenger side, right, and C1600SD-R (top of mirror).

**C1600SD-LR (bottom of mirror)**

Driver side, left      Passenger side, right

**C1600SD-R (top of mirror)**

COMPANY CONFIDENTIAL  
© 2019 SmartDrive Systems, Inc. This information is intended for use by SmartDrive customers only. Any other use without the express written consent of SmartDrive Systems, Inc. is strictly prohibited.

**SMARTDRIVE**  
Rev 1, March 29, 2019

[RETURN HOME](#)

---

# ADAS Camera and Driver Feedback Device

---

# International DuraStar (MA025)

## Approved ADAS Forward-facing Camera location

### Mounting Location

Mount the ADAS shroud 1" from the top and center of the windshield

The camera cannot interfere with a driver's line of sight of the road, traffic signals, or road signs.

### Details

1. Before removing the adhesive backing, check to make sure the camera fits properly
2. Using an alcohol pad clean the windshield and wipe dry with a lint-free clean cloth
3. **Critical: Use a pocket level to ensure that the bottom of the camera is mounted level looking from left to right.**
4. Press firmly on camera bracket for 10 seconds to ensure adhesion
5. Run camera cable under the headliner towards the driver side
6. Remove the A-pillar cover and run the camera cable down to the controller. Ensure the cable doesn't get pinched.

**This camera requires calibration.**  
**Details are available in the**  
**ADAS installation and Calibration guide**





# International DuraStar (MA025)

## Driver Feedback Device location

### Mounting Location

**Mounted on the right hand side of the steering wheel to the top of the dash.**

**Run the cable to the controller.**

**Plug the driver feedback cable into the port DRIVER FB**

**Secure the device by cleaning the area with alcohol pad and secure with adhesive**

### Details

1. The sensor bar must be visible to the driver.
2. Clean the windshield with an alcohol pad and wipe dry with clean cloth. Do not use shop rags which have grease even when clean.
3. Press firmly on the baseplate for 10 seconds to ensure it adheres properly to the dash
4. Secure with 2 self-tapping screws
5. Run wires to the controller



---

# Best Practices: Cameras, Sensor Bar, & Keypad

---

# International DuraStar (MA025)

## Best Practice: Camera Mounting Considerations

During an install, you may find obstructions such as sun visors and third party devices that make it impossible to mount in a SmartDrive approved location. The following describes our recommended adjustments in these situations.

**Sun Visors are set in the down position and fully extended** during the install process to verify the Cab-facing camera has a clear view of the drivers face, hands on the steering wheel, shoulder, and seat or lap belt. When blocked by visor, mount the Cab-facing camera using the secondary location where the desired view is attainable.

**When third party devices are located at the top center of the windshield,** mount the forward-facing camera on the right side of the device.

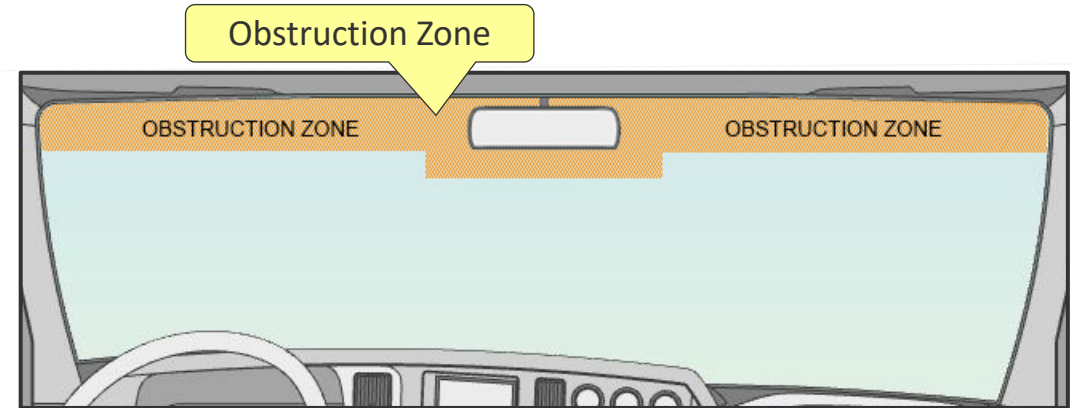

# International DuraStar (MA025)

## Best Practice: Forward and Cab-facing Camera Installation Instructions

### Forward-facing Camera Installation Instructions



**Mount the camera within 6" from the top of the windshield.  
Camera cannot interfere with a driver's line of sight  
to the road, traffic signals, or road signs**

#### Details

1. Before removing the adhesive backing, check to make sure the camera fits properly. **Use a pocket level to ensure the bottom of the camera is mounted level looking from left to right.**
2. Using an alcohol pad clean the windshield and wipe dry with a lint-free clean cloth. Do not use shop rags which contain grease even when clean.
3. Press firmly on camera bracket for 10 seconds to ensure adhesion
4. Use ¼ loom to protect the cable and to keep it from coming loose from the headliner
5. Run the camera cable down to the controller.
6. Cables must not block air bag functionality

### Cab-facing Camera Installation Instructions



**Camera lens must have a complete view of the driver when the visors are in the down and fully extended position. Use a headliner location when the fully extended visor covers the camera lens.**

#### Details

1. Mount the Cab-facing camera on a flat hard surface Using an alcohol pad clean the windshield and wipe dry with a clean cloth. Do not use shop rags which contain grease even when clean.
2. **Mount the camera where the sun visor does not block the lens** (windshield or headliner)
  - Headliner: Secure with 2-3 self-tapping screws
3. Press firmly on camera bracket for 10 seconds to ensure adhesion
4. Use ¼ loom to protect the cable and to keep it from coming loose from the headliner
5. Run the camera cable to the controller
6. Cables must not block air bag functionality
7. Ensure the cable doesn't get pinched



# International DuraStar (MA025)

## Best Practice: Cab-facing Camera Installation Instructions regarding Infrared Light

### Cab-facing Camera Headliner Mount

The cab-facing camera has two infrared (IR) sensors that improve image quality when the cab is dark. IR flare occurs when the camera bracket partially blocks the cab-facing camera creating a bright flare in the image. (See image 1)

### Proper Headliner Mounting Options

The camera face must extend beyond the bracket to prevent obstruction

### Vertical Mount

Mount the camera vertically to the headliner and position the bracket to hang toward the road. Rotate the camera level with the road and tilted down slightly toward the driver. There should be a visual air gap between the camera and bracket (see all the way through). (See image 2)

### Horizontal Mount

Mount the camera horizontally to the headliner and tilt the bracket forward parallel with the headliner. Rotate the camera level with the road and tilt it down toward the driver. There should be a visual air gap between the camera and bracket (see all the way through). (See image 3)

**Make sure the cab-facing camera bracket, or vehicle's headliner, DOES NOT BLOCK the cameras Infrared (IR) sensors**

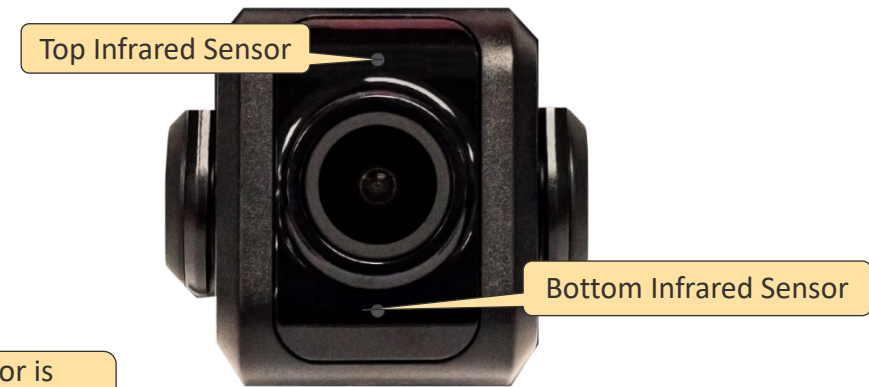

Infrared Sensor is obstructed by the bracket



# International DuraStar (MA025)

## Best Practice: Forward-facing Camera – Field of View Adjustment

### Use the proprietary M4 security wrench

1. Loosen the camera bracket screws located on the Forward-facing camera mounting bracket shaft
2. Adjust the camera angle by rotating and/or tilting the camera slightly down to capture the view of the horizon to see an unobstructed view of the road and traffic signals/signs in front of the vehicle
  - **Note:** It is not required to remove the camera from the mounting bracket to complete this adjustment
3. Tighten camera bracket screws when the proper camera angle placement is achieved

Note: These are stock images which are not specific to this vehicle.

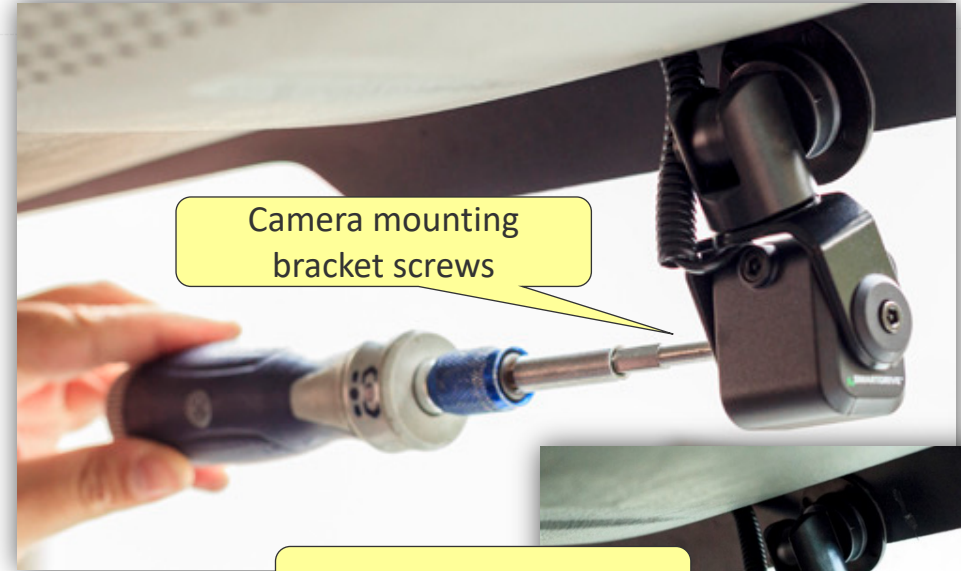

# International DuraStar (MA025)

## Best Practice: Acceptable Camera Views

### Forward-facing camera view



The field of view shows a small portion of the hood while maintaining view of horizon to see road and traffic signals/signs.

### Cab-facing camera view

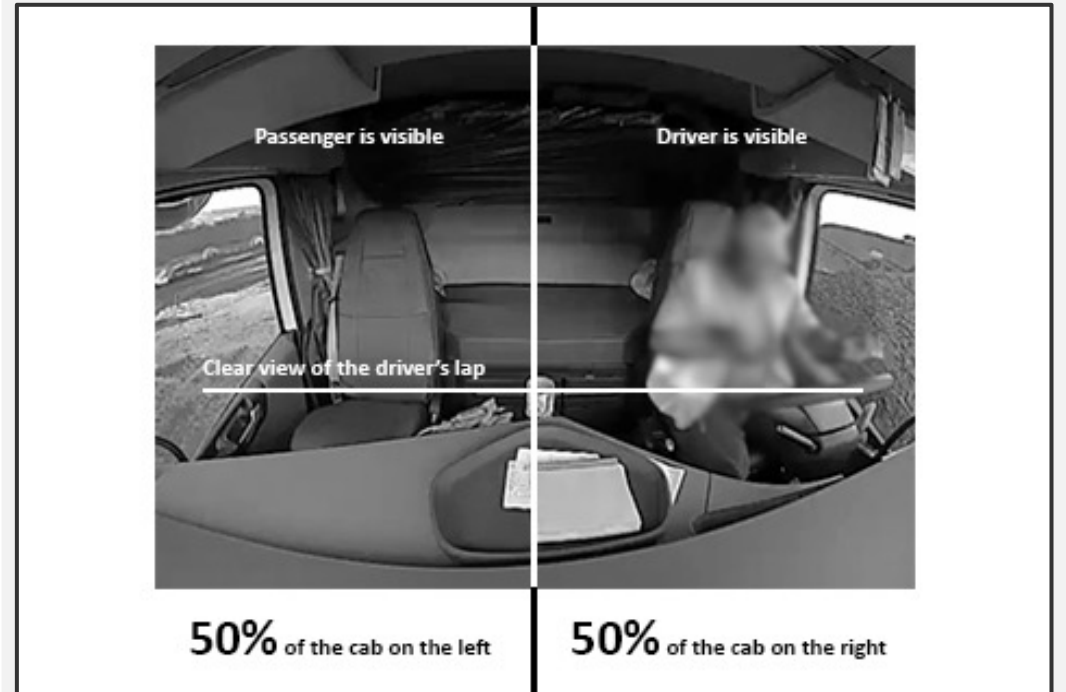

The camera placement is ideal if the field of view provides an unobstructed view of the driver's head / eyes, lap, hands, seatbelt, and an adequate view of the steering wheel (i.e., a visual approximation of at least 75% of the wheel visible within the frame).

# International DuraStar (MA025)

## Best Practice: Sensor Bar and Keypad Installation Details

### Sensor Bar Installation Details

See Sensor Bar slide for location information

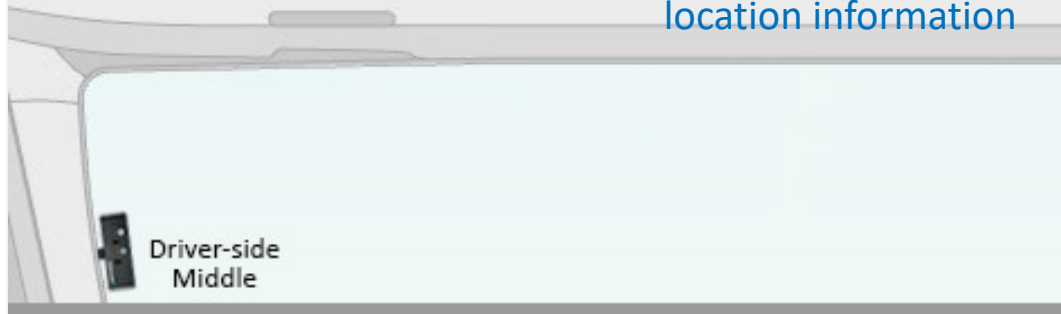

1. The sensor bar must be visible to the driver. Do not mount where a visor in the down position or fully extended can block the drivers view of the sensor bar.
2. Clean the windshield with an alcohol pad and wipe dry with clean cloth. Do not use shop rags which have grease even when clean.
3. Remove the baseplate from the sensor bar.
  - DO NOT lose the screws
4. Press firmly on the baseplate for 10 seconds to ensure it adheres properly to the windshield
5. Install the sensor bar and secure screws until tight
6. Run sensor bar wires to the controller
7. Ensure the cable does not prevent the functionality of an airbag

### Keypad Installation Details

See Keypad slide for location information

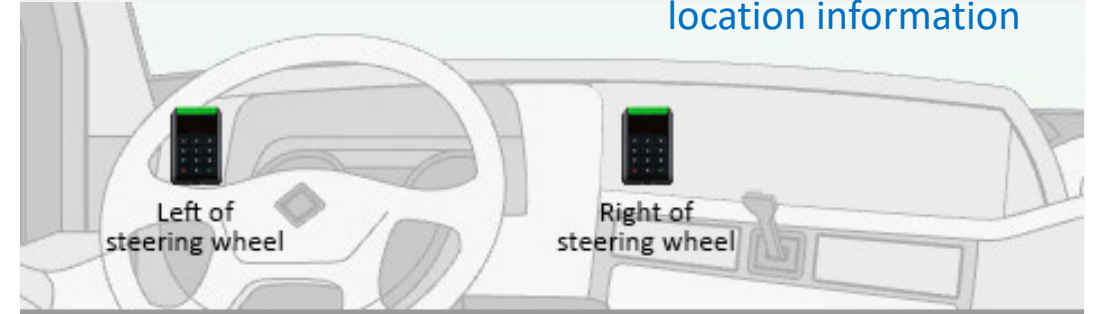

1. Mount keypad bracket and secure the bracket with 2 self-tapping screws
2. Run the length of the keypad cable behind the dashboard to the controller location.
3. If needed, drill a 3/4 inch hole in the dash and insert a 3/4 inch snap bushing into the hole to protect the cable from sharp surfaces
4. Inspect the backside of the box & verify that the screws don't protrude and cause damage
5. Insert keypad into mount



# International DuraStar (MA025)

## Best Practice: Cable Routing

### Service Loops

Before connection cables to the controller, coil excess wiring in an 8" loop and secure with zip ties

### Zip Ties

Use zip ties as needed to secure wiring

### Controller SMB Connectors

Press down on each SMB Coaxial connector to ensure a good connection

### Molex Connectors

Push and lightly pull each Molex connector to ensure that the snap-in clip is secure

### OBDII Connectors

Use SmartDrive banded zip ties around the connectors to prevent them from coming loose and to identify tampering

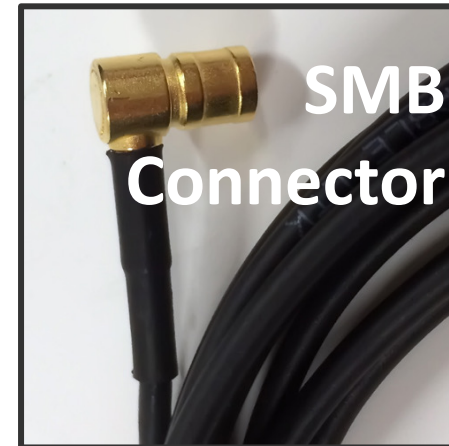
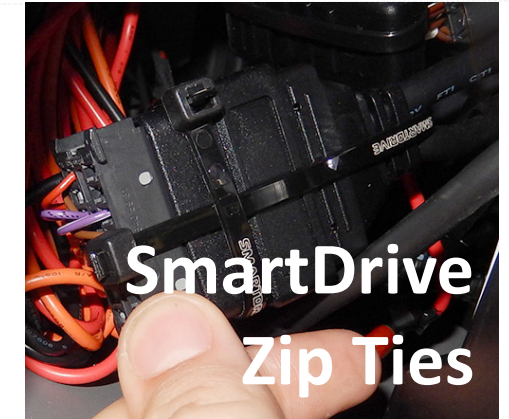
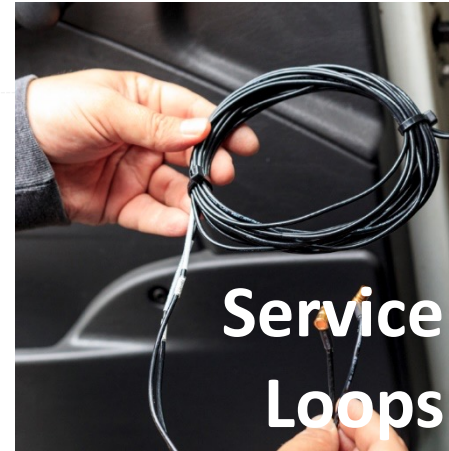



---

# Controller: Wiring and Component Connections

---

# International DuraStar (MA025)

## Approved and Non-Approved Electrical Connection Methods

### Approved Electrical Connections

Approved connections methods are with **(Permanent Connections)** – Heat Shrinkable and Water Resistant connectors.

Ring Terminals ✓



Spade Terminals ✓



Add-a-Fuse ✓

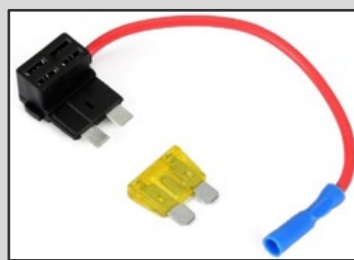

Butt Connectors ✓

16-14 Awg.		
12-10 Awg.		
8 Awg.		

### Non-Approved Electrical Connections

**Scotchloks or T-Taps** are **NOT** allowed. These connections are prone to corrosion, loosening, are easily tampered. They can result in less than desirable performance issues.

Scotchlok (Wire Nuts) ✗



Scotchlok (T-Tap) ✗



Inline Wire Tap ✗

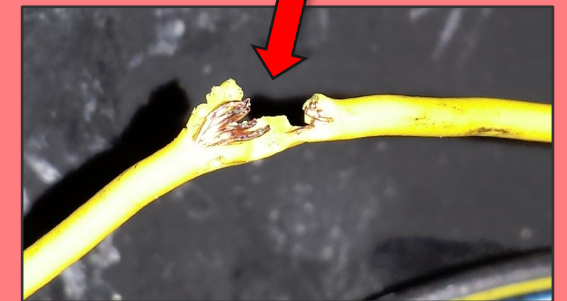
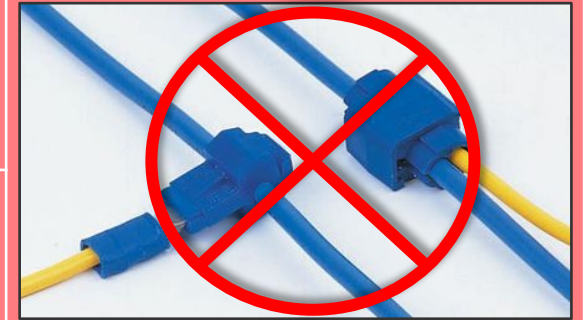

# International DuraStar (MA025)

## Verifying Wiring Connecting

### +12v (Uninterrupted) Constant Power

#### (Red Wire)

How to locate Constant Uninterrupted Power with a Digital Multi-meter:

1. Test for constant 12 volts (in all key positions)
2. With the ignition ON, vehicle running, Ignition OFF, and while cranking.
3. Verify constant battery voltage remains constant and does not drop below 10vDC

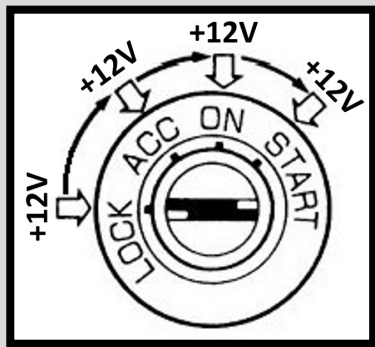

### +12v True-Ignition

#### (Orange Wire)

How to locate True Ignition with a Digital Multi-meter:

1. With the vehicle off your meter will show "0" volts.
2. With the key in the Run position your meter will show approx. 11 ~ 14 volts.
3. While the vehicle starter is cranking, your meter will show approx. 10 ~11 volts.
4. With the engine running your meter will show approx. 12 ~ 14 volts.

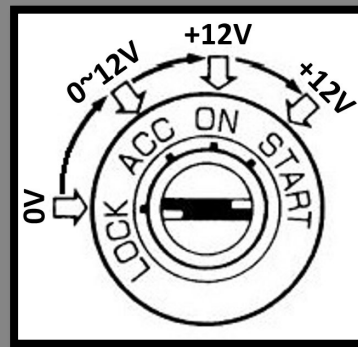

### (Chassis) Ground

#### (Black Wire)

Verifying Chassis Ground

Connect a #10 ring terminal to the black ground wire. When making a connection in the engine compartment, use a #10 water resistant, heat shrinkable ring terminal. Scrape surface near the vehicles fuse box and use ¼ inch self-tapping screw to connect the ground wire

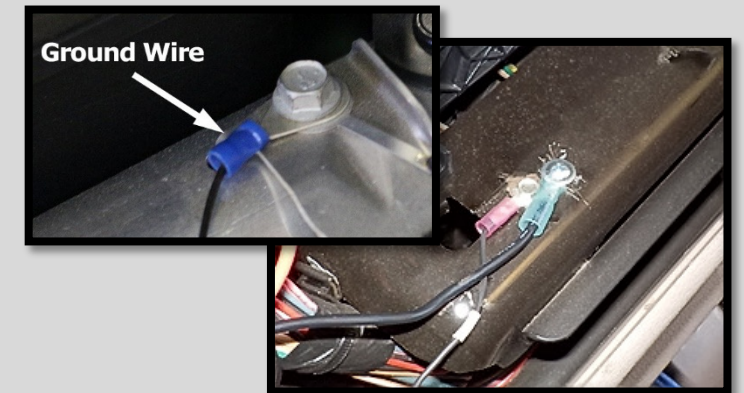



# International DuraStar (MA025)

Master Power Cutoff (MPC) and Low Voltage Disconnect (LVD)



## Negative Ground Master Power Cut-off Switch (-MPC)

**NEVER** connect to:

(-) Negative Ground (MPC)!

## Positive Master Power Cut-off Switch (+MPC) and LVD

**ONLY** connect to:

- Positive Post of Vehicle Battery.
- Hot/Battery side of (+MPC) Switch.
- Hot/Battery side of (LVD).

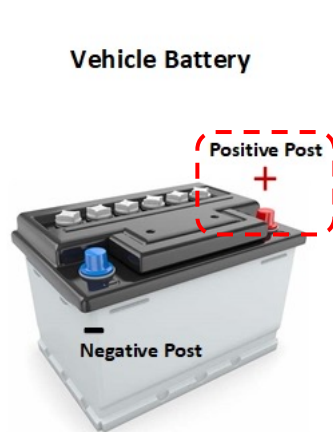

Connect the SmartRecorders **Red** Constant Power wire to the **Positive Post** of the Vehicles Battery.

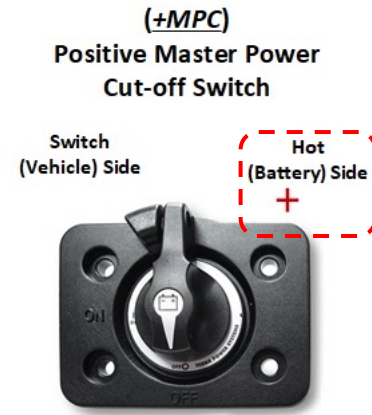

Connect the SmartRecorders **Red** Constant Power wire to the **Hot/Battery** side of the Master Power Cut-off switch.

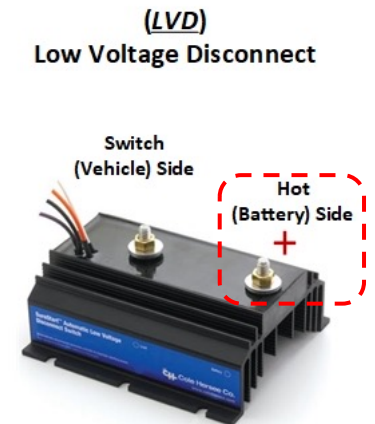

Connect the SmartRecorders **Red** Constant Power wire to the **Hot/Battery** side the Low Voltage Disconnect.

**The SmartDrive SR4 system is designed to function only with a Positive MPC/LVD, not a Negative Ground MPC/LVD.**

# International DuraStar (MA025)

Controller Connection Ports: DLC/Power, Analog Power, Keypad, Sensor Bar, GPS, Wabco Camera, GPS, Remote Push Button

## Expansion Port

Plug the expansion cable to the EXPANSION port

## ECU/Controller connection and Power

Plug the main power and ECU connector to the ECU/PWR port

## Analog Power

Plug the Analog Camera Power connector to the Analog PWR port

## Driver Feedback

Plug the driver feedback cable into the port DRIVER FB

## The Keypad

Connect the Keypad connector to the KEYPAD port

## The Sensor Bar

Connect the Sensor Bar connector to the blue SENSOR BAR port

## Wabco Camera

Plug the Wabco camera connector to the WABCO CAM port

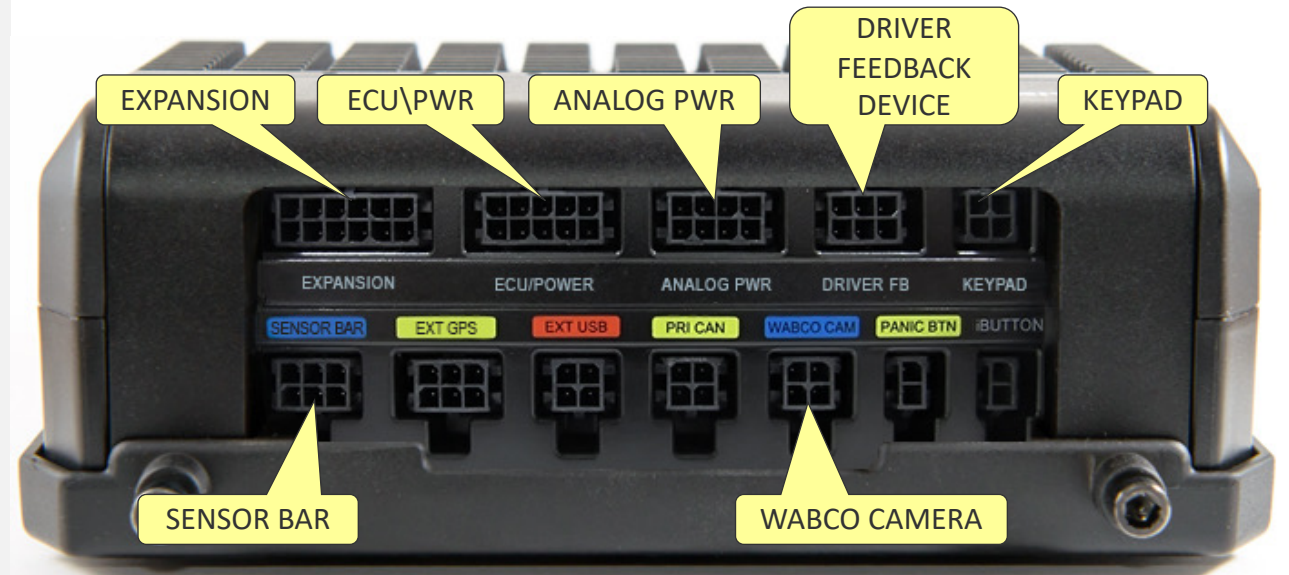

# International DuraStar (MA025)

## Controller Connections: Forward and Cab-facing cameras and Sensor Bar (Cellular and WIFI)

### Connection instructions

1. Forward-facing Camera (FWDCAM-1 port)
2. Cab-facing Camera (DCAM-2 port)
3. Reserved (DCAM-3 port)
4. Other Digital Camera (DCAM-4 port) (not available)
5. Cellular Antenna (CELL ANT port)
6. WIFI Antenna (WIFI ANT port)

### Details

Connect all cables to their ports and route through the strain relief channel. Use mounting tray for securing the Controller

Please take extra care when routing and tying up the camera cables as kinks or tight cable ties may create video failure

Depress the SMB coaxial connector until it clicks (locks) in place then route the cable in the strain relief channel

Should you need to remove a cable, use the cable puller

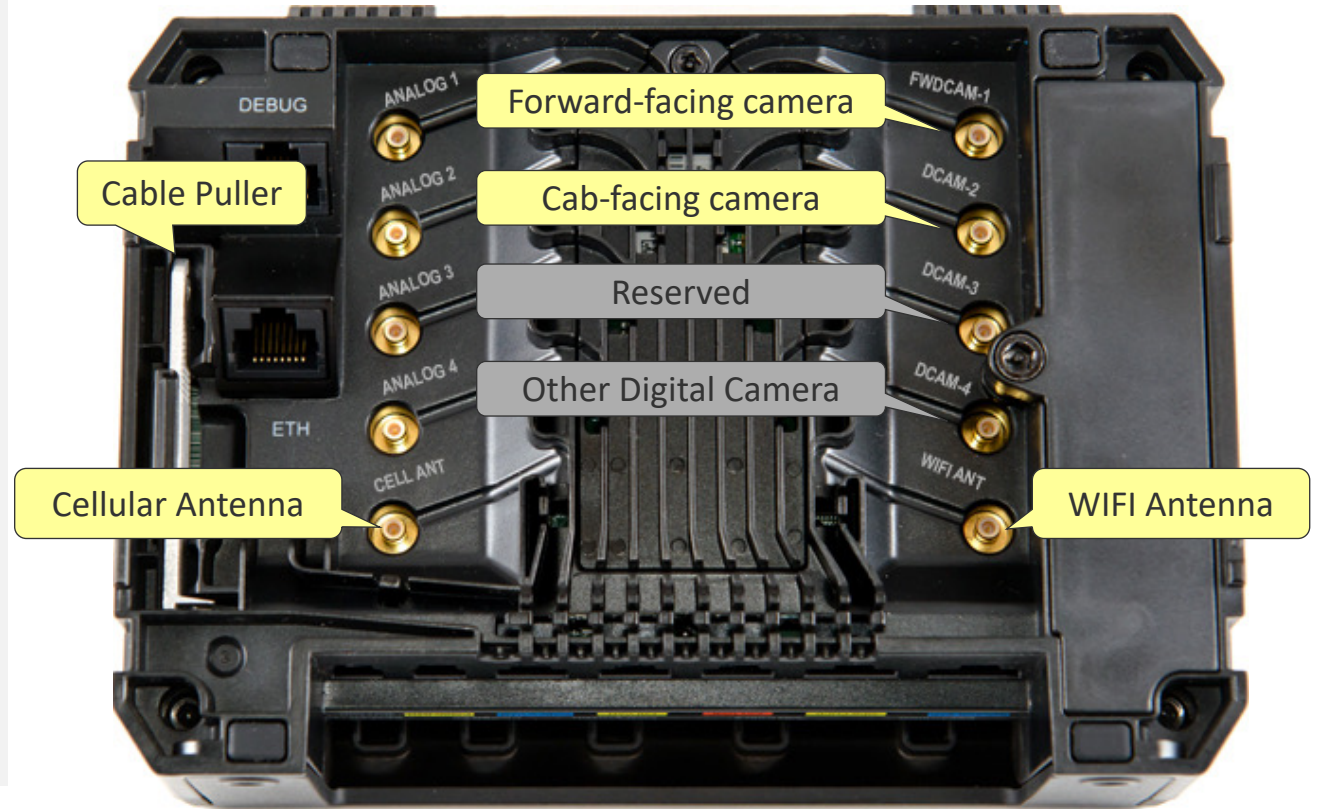



# International DuraStar (MA025)

## Controller Connections: Analog cameras

### Connection instructions

- Analog 1: 360 camera mounted on the passenger-side
- Analog 2: 360 camera mounted on the driver-side
- Analog 3: Any other analog camera (backup, rear view, etc.)
- Analog 4: Not available

### Details

Connect all cables to their ports and route through the strain relief channel. Use mounting tray for securing the Controller

Please take extra care when routing and tying up the camera cables as kinks or tight cable ties may create video failure

Depress the SMB coaxial connector until it clicks (locks) in place then route the cable in the strain relief channel

Should you need to remove a cable, use the cable removal tool







# International DuraStar (MA025)

## System Verification

Once the Controller is powered up, use the 3 LEDs on the top of the Controller to verify proper operation

- ✓ **Power LED** 
  - ✓ Solid **red** when control is receiving external power
  - ✓ OFF when not powered
- ✓ **Ignition LED** 
  - ✓ Solid **orange** when ignition is on
  - ✓ OFF when ignition is off
- ✓ **System LED** 
  - ✓ OFF when the controller is shut down
  - ✓ ON green, awake and running with constant power
  - ✓ **BLINKING green**, awake and running **ONLY** on the controllers internal battery. Action: Rewire to obtain constant power.



[RETURN HOME](#)

---

# Diagnostic Mode and Self QA

---

# International DuraStar (MA025)

## Preparing Diagnostic Mode and checking cellular connectivity

1. **Move the vehicle outside** to obtain cellular connectivity
2. **Start/Crank the vehicle and let it run for 30-60 seconds** before triggering an event to ensure ECU data is being gathered.
3. **Turn the windshield wipers on** to ensure the Road-Facing camera is in the windshield wiper path.
4. **Fully extend and place all windshield visors down** to ensure the Cab-Facing camera has a clear view of the driver (no obstructions).
5. **Verify the system has a cellular connection** by observing a solid blue gear LED on the Sensor Bar.

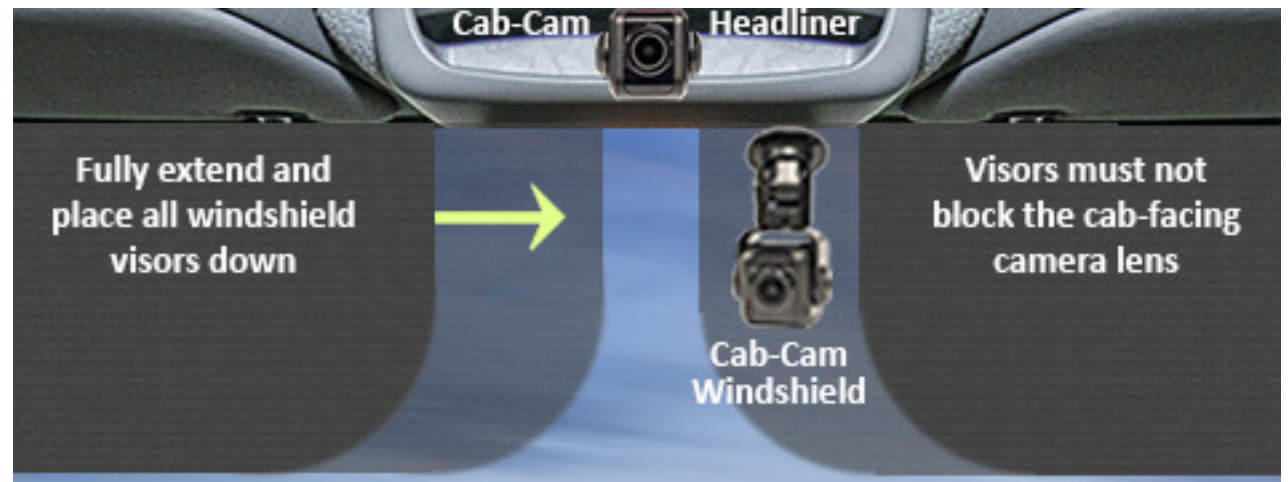

# International DuraStar (MA025)

Run Diagnostic Mode using the Keypad or Driver Feedback Device

Press the green button on the keypad or driver feedback device 5 times in 10 seconds to initiate Diagnostic Mode

When diagnostic mode is complete, it will display all Zeros (000000).

Press the green button one time to create a manual event.

Note: The SR4 Controller will reboot after the test is complete.



When the test identifies a SR4 system fault, a code will display on the keypad or the driver feedback device. Fault codes are cumulative

*Example:*

Sensor Bar not found (020,000)

Ignition Off (010,000)

The error codes are added together. 030,000 will display.

When the keypad displays a fault code, use the [SR4 Installation Checklist and Diagnostic Mode/Fault Code Guide](#) to assist you in resolving the problem. This document is available from your SmartDrive Project Manager or online in the Response Center help page.

If you can't resolve a fault code, contact **Technical Support**.

Toll free number **(866) 933-9930 Option 1**



#### What is Diagnostic Mode?

Diagnostic Mode is an environment that runs a set of tests on the SmartRecorder™ 4 (SR4) in order to identify any faults that may be occurring. Diagnostic Mode utilizes the SR4 Keypad and Driver Feedback Device to display fault codes.

#### Run Diagnostic Mode after every installation or repair

Diagnostic Mode codes will display any appropriate fault codes on the keypad and the driver feedback device.

Fault codes appearing on the keypad are cumulative

Example: Sensor Bar not found (020000) + No GPS Signal (000100) = 020100

#### How to Exit Diagnostic Mode?

To exit Diagnostic Mode, turn the Ignition OFF and wait 15 seconds.

#### Diagnostics Mode Fault Codes

Keypad Code	Code Description	Action
000000	Diagnostic Mode has completed with no faults	None – Passed
000001	Analog camera enabled and not detected	Often referred to as "360 cameras", ensure you would expect analog Cameras to provide feed during the diagnostics test. Refer to your Vehicle Spec for connectivity or contact technical support for further assistance
000002	Analog Camera Capture Circuit	Contact technical support for assistance with this code
000004	Audio Fault	Contact technical support for assistance with this code
000010	Wi-Fi Wireless signal found but unable to connect to SmartDrive	Verify the Vehicle is in WIFI coverage area; check your facility Wi-Fi setup. If correct, contact technical support
000020	Wi-Fi Modem Fault	Perform a soft reboot (10 key presses in 10 seconds) Wait 5 minutes for system to reboot, re-run diagnostic test again. If the fault does not clear, contact technical support



# International DuraStar (MA025)

## Run Self-check (Diagnostic Mode) using the SmartDrive Technician App

Perform self-service installation QA via a mobile device

- The Android App is available in the Google Play Store.
- Run Self-Check.
- When the SR4 Condition is green, you are done.
- When the SR4 Condition is red, the problem area is shown in red. Resolve that problem area and run Self-Check again.

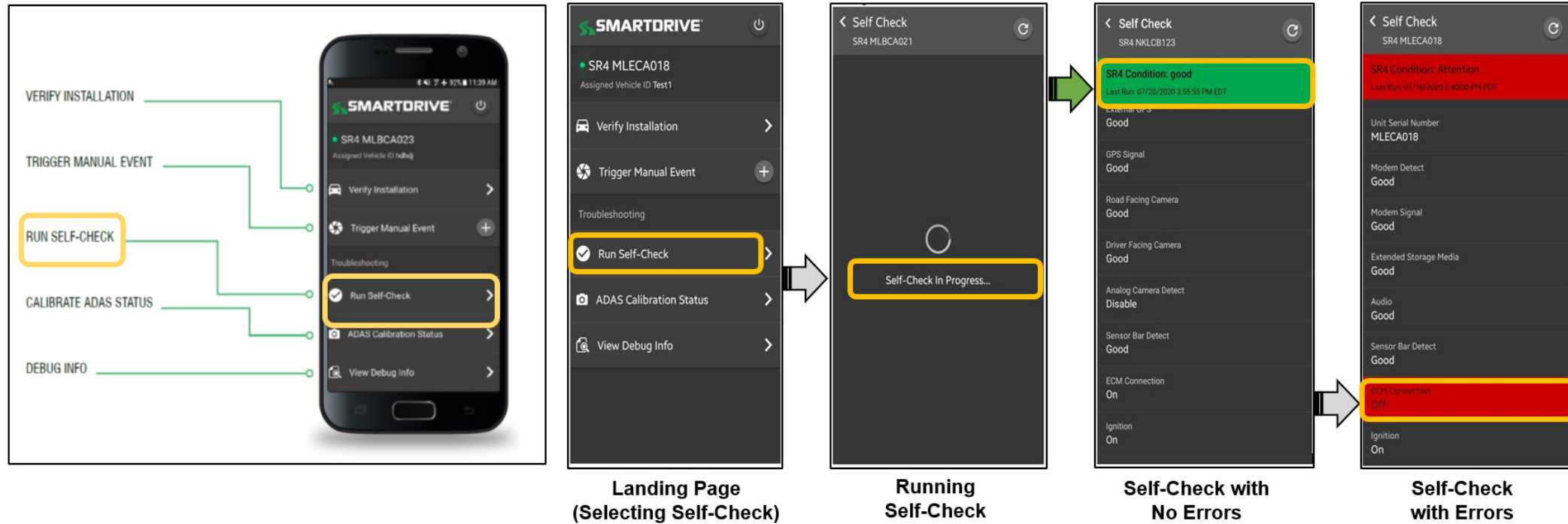



# Approved Exceptions

# International DuraStar (MA025)

## Vehicle Specification Assessment (VSA) & Exception Management

### VSA - MASTER INSTALL SPECIFICATION

The VSA is the approved hardware installation and wiring spec for this vehicle make-model and year ranges

Specific details are defined within – **check the model year you are installing on** as it specifies:

- ✓ Appropriate SmartDrive wiring harness to use
- ✓ Location and instructions for the approved Data Link Connector (DLC)
- ✓ Approved locations and install details for cameras, controller, keypad, and sensor bar
- ✓ The source and approved method to obtain uninterrupted constant power, true ignition, and chassis ground
- ✓ How to connect cables to the controller
- ✓ How to test, troubleshoot, and diagnose
- ✓ How to call into Technical Support for final QA validation

### CAUTION:

### EXCEPTION MANAGEMENT

- Contact** your SmartDrive Project and Account Manager if anything within this document cannot be followed
- Toll free number **(866) 933-9930 Option 1** or their direct phone number
- All exceptions** must be documented and approved by SmartDrive and Customer before proceeding with installations

# International DuraStar (MA025)

Document all Approved Exceptions

N/A

Approved by